



INSTALLATION, OPERATION & MAINTENANCE

VERTICAL BELT DRIVE BLOWER COIL UNITS

MODELS SSL & SBS



TABLE OF CONTENTS

TABLE OF CONTENTS	2
SAFETY SYMBOLS	2
SAFETY CONSIDERATIONS.....	3
PRE START-UP	4
Receiving and Inspecting	4
Unit Rigging and Placement.....	4
Clearance	4
FIELD WIRING	4
BELTS, DRIVES, AND BEARINGS	5
DETERMINING DEFLECTION FORCE.....	5
REPLACEMENT PARTS	6
PIPING.....	6
CONDENSATE DRAIN AND TRAPS.....	7
GENERAL BELT AND BEARING MAINTENANCE	8
MOTOR ELECTRICAL DATA.....	9
UNIT WEIGHT DATA.....	9
MOTOR/DRIVE WEIGHT DATA.....	9
MODEL SSL ARRANGEMENTS.....	10
MODEL SBS ARRANGEMENTS	10
INSPECTION & START-UP CHECKLIST	11
DIMENSIONS.....	12
Model SSL Basic Unit - Discharge Arrangement 2.....	12
Model SSL Basic Unit - Discharge Arrangement 1 with Blow-thru Electric Heat.....	13
Model SBS Basic Unit - Discharge Arrangement 2	14
Model SBS with Inlet Damper Section (Requires Base rail) - Discharge Arrangement 2	15
3 Inch Baserail Assembly	16
Model SSL/SBS Discharge Plenum, Sizes 08-30	17
Model SSL Return Plenum, Sizes 08-30	18
Model SSL/SBS Discharge Section w/ Heating Coil, Sizes 08-30	19

SAFETY SYMBOLS

The following symbols are used in this document to alert the reader to areas of potential hazard:



DANGER indicates an imminently hazardous situation which, if not avoided, will result in death or serious injury.



CAUTION identifies a hazard which could lead to damage to the machine, damage to other equipment and/or environmental pollution. Usually an instruction will be given, together with a brief explanation.



WARNING indicates a potentially hazardous situation which, if not avoided, could result in death or serious injury.

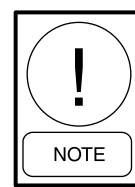

NOTE is used to highlight additional information which may be helpful to you.

SAFETY CONSIDERATIONS

The equipment covered by this manual is designed for safe and reliable operation when installed and operated within its design specification limits. To avoid personal injury or damage to equipment or property while installing or operating this equipment, it is essential that qualified, experienced personnel perform these functions using good judgment and safe practices. See the following cautionary statements.



ELECTRICAL SHOCK HAZARDS. All power must be disconnected prior to installation and servicing this equipment. More than one source of power may be present. Disconnect all power sources to avoid electrocution or shock injuries.



MOVING PARTS HAZARDS. Motor and Blower must be disconnected prior to opening access panels. Motors can start automatically, disconnect all power and control circuits prior to servicing to avoid serious crushing or dismemberment injuries.



HOT PARTS HAZARDS. Electric Resistance heating elements must be disconnected prior to servicing. Electric Heaters may start automatically, disconnect all power and control circuits prior to servicing to avoid burns.



Check that the unit assembly and component weights can be safely supported by rigging and lifting equipment.



All assemblies must be adequately secured during lifting and rigging by temporary supports and restraints until equipment is permanently fastened and set in its final location.



All unit temporary and permanent supports must be capable of safely supporting the equipment's weight and any additional live or dead loads that may be encountered. All supports must be designed to meet applicable local codes and ordinances.



All fastening devices must be designed to mechanically lock the assembly in place without the capability of loosening or breaking away due to system operation, vibration, impact or seismic event.



Secure all dampers when servicing damper, actuator or linkages. Dampers may activate automatically, disconnect control circuits or pneumatic control systems to avoid injury.



Protect adjacent flammable materials when brazing, Use flame and heat protection barriers where needed. Have fire extinguisher available and ready for immediate use.

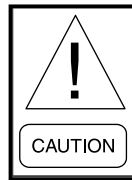

Improper installation, adjustment, alterations, service or maintenance can cause injury and property damage, as well as possible voiding of factory warranty. For assistance or additional information, consult a qualified contractor.



The unit's Intertek listing specifies a maximum external static pressure of 1.35" when a unit is selected with Electric Heat; operation above this limit exceeds the certified parameters.

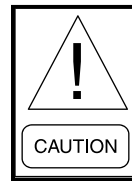

The auto air vent must not be used with Glycol to ensure compliance and safe operation.

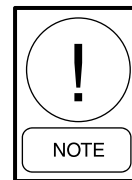

This unit is ETL listed to UL/CSA standards. Specifically, it conforms to UL Std. 60335, Cert. to CSA Std. C22.2 No. 60335. All modifications to line voltage wiring must be performed in accordance with the NEC and inspected by ETL to maintain listing. Unauthorized modification to any wiring may impact unit performance and void ETL listing and/or product warranty.

PRE START-UP

Receiving and Inspecting

Thoroughly examine the exterior and interior of all units for transportation damage to the cabinet, piping, blower(s), motor(s), coil(s), electric heat and electrical components. Interior damage may occur, even with no visible exterior damage. If damage is found, immediately file a claim with the carrier. Note the damage on the bill of lading before signing for the shipment.

Check the bill of lading for verification that all items shown (including loose items) have been received. Notify the manufacturer's representative of any shortages or items shipped in error.

Unit Rigging and Placement

Install ductwork to comply with ASHRAE Fundamentals Handbook, SMACNA, NFPA 90A and local code.

The installation must conform with local building codes and the National Electric Code.

Locate unit support in accordance with the mechanical and structural plans. If so equipped, locate the isolator placement and correct size as shown on the submittal drawing.

If floor mount isolators are required, factory or field provisions must be made for isolator attachment. Units can be mounted directly to the floor or on a base rail. The optional base rail is recommended for units with isolators.

Do not handle the unit using coil stubout connectors, as damage may occur at brazed joint(s).

Clearance

All units, including those with electric heat, are listed for zero clearance to combustibles.

Sufficient clearance for normal servicing of this equipment is recommended.

All electrical panels must have 36" working space in front of panel to meet National Electric Code; however, local inspectors may waive this requirement if the hinged cover has a 90° free swing.

FIELD WIRING

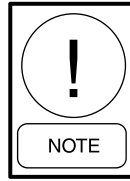

Prior to installing any wiring, check the unit name plate for main power voltage, control voltage, transformer sizing and any fuse sizing. All field wiring must comply with National Electric Code and local code requirements.

Tighten all wiring lugs and terminals prior to connecting power to the unit, as they may loosen during transportation.

Route the power lines to the power distribution terminals inside the control enclosure. If a factory wired disconnect switch is installed, then connect the power lines to the line side of the switch.

Mount and wire any field installed items as indicated on the factory supplied wiring diagram. When mounting field installed components, do not jumper out or rewire any factory wiring without written approval from Superior Rex. Violation will void warranty.

BELTS, DRIVES, AND BEARINGS

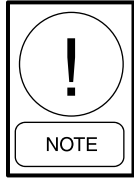

For safety, please turn off all power before checking belt tension.

Prior to starting the unit, tighten all set screws on the fan(s), sheaves and bearings where applicable. Set screws may loosen during transportation.

Sheaves must be in line. Use a straight edge to verify.

General belt tension rules for V-Belt drives:

- Ideal tension is the lowest tension at which the belt will not slip under peak load conditions.
- Check tension frequently during the first 24-48 hours of operation.
- Over tensioning shortens belt and bearing life.
- Keep belts free from foreign material which may cause slip.
- Make V-Belt inspection on a periodic basis. Tension when slipping. Never apply belt dressing, as this will damage the belt and cause early failure.
- The resilient blower bearing must not deflect laterally once belt is tightened.

DETERMINING DEFLECTION FORCE

(see Fig. 1)

Example	Solution
Belt Span = 20" Belt Type – A, new, unnotched RPM = 1000 Small Sheave Diameter = 4.0"	Deflection = $20 \div 64 = .313$ " (round to 5/16"). <i>Referring to table below, deflection force at calculated deflection is 6.8lbs.</i>

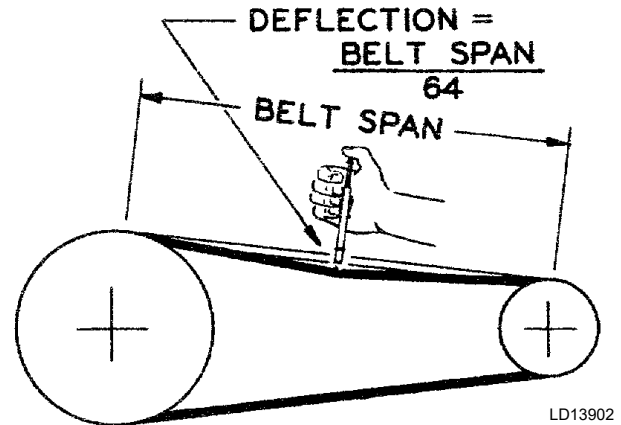

FIG. 1 - COMPUTING DEFLECTION FORCE

See table below for deflection force in pounds.

DEFLECTION FORCE — LBS.

Belt Type	Smallest Sheave Diameter Range	RPM Range	Super Gripbelts and Unnotched Gripbands		Gripnotch Belts and Notched Gripbands	
			Used Belt	New Belt	Used Belt	New Belt
A, AX	3.0 - 3.6"	1000 - 2500	3.7	5.5	4.1	6.1
	3.8 - 4.8"	1000 - 2500	4.5	6.8	5.0	7.4
	5.0 - 7.0"	1000 - 2500	5.4	8.0	5.7	9.4
B, BX	3.4 - 4.2"	860 - 2500	Not Recommended		4.9	7.2
	4.4 - 5.6"	860 - 2500	5.3	7.9	7.1	10.5
	5.8 - 8.6"	860 - 2500	6.3	9.4	8.5	12.6

LD13903

REPLACEMENT PARTS

Replacement parts may be ordered from the local Superior Rex representative. Factory replacement parts should be used wherever possible to maintain agency listings. Should replacement parts not be purchased from the factory, use only parts duplicating the exact type, size, voltage and other operating characteristics of the original part. Contact the local representative before using any substitute part or making unit modifications. Any substitutions and/or modifications not authorized by the factory will void the unit warranty and could result in personal injury and/or property damage.

When ordering parts, the following information must be supplied to ensure proper part identification:

1. Complete unit model number
2. CO number from the unit nameplate
3. Complete parts description, including any identification numbers.

PIPING

- All piping must comply with applicable state and local codes.
- On water coils, the piping must be in a counter-flow configuration; water inlet on the leaving air side of the coil and at the bottom of the coil to provide the necessary purging of air.
- All water piping should be designed and installed to meet the job requirements.
- Where applicable, freeze protection should be used.
- Supply and return water piping should be supported. Do not suspend piping, controls, and/or shutoff valves from coil headers.

COOLING/HEATING MEDIUM CONNECTIONS



Toxic residues and loose particles resulting from manufacturing and field piping techniques such as joint compounds, soldering flux, and metal shavings may be present in the unit and the piping system. Not for use with domestic or potable water systems.

Submittals and Product Catalogs detailing unit operation, controls, and connections should be thoroughly reviewed BEFORE beginning the connection of the various cooling and/or heating mediums to the unit.

Hot water and cooling coils are male sweat connection. Use appropriate brazing alloy for system temperature and pressure. Refer to equipment construction submittal drawing for specific connection size. **MAXIMUM HYDRONIC SYSTEM OPERATING PRESSURE MUST NOT EXCEED 450 PSIG.**

All factory provided or field provided valve packages are to be installed as required, and all service valves should be checked for proper operation. Refer to the valve component manufacturer's submittals and/or IOM manual for proper installation, troubleshooting, and operational guidance.

Valves must be secured and supported to avoid damage to coil headers or distributor tubes. All valves, pipes, and components must be sufficiently supported to ensure structural integrity and proper operation of the unit.

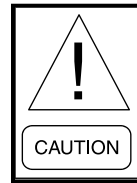

All water coils must be protected from freezing after initial filling with water. Even if the system is drained, unit coils may still hold enough water to cause damage when exposed to temperatures below freezing.

After system integrity has been established, the piping should be insulated in accordance with the project specifications. ALL chilled water piping and valves not located over drain pans must be insulated to prevent damage from sweating. This includes factory and field piping inside the unit cabinet.

The drain should always be connected and piped to an acceptable disposal point. For proper moisture carry-off, the drain piping should be sloped away from the unit at least 1/8" per foot. A drain trap may be required by local codes and it is strongly recommended for odor containment.

CONDENSATE DRAIN AND TRAPS

Drain lines should be at least the same size as the drain pan connection. Properly sized traps should be used to allow the condensate from the coils to drain from the drain pan. *See Fig. 2.*

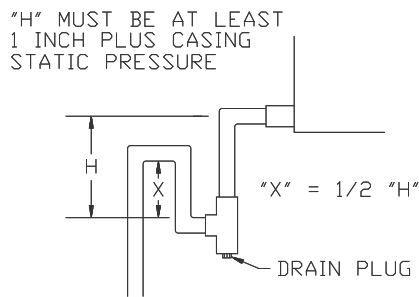

Trap detail for negative cabinet static pressure

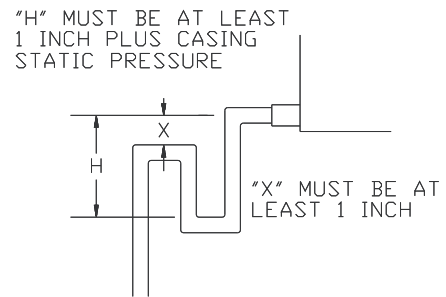

Trap detail for positive cabinet static pressure

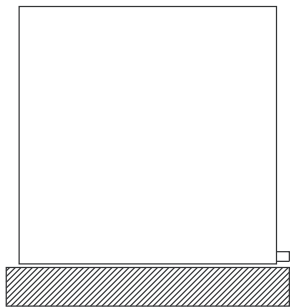

NO BASE RAIL

Housekeeping pad
Required to accommodate trap height

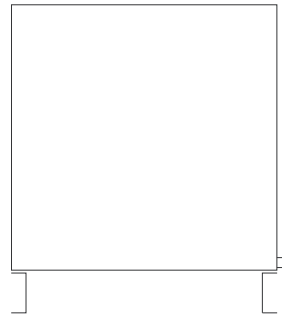

WITH BASE RAIL

Depending on static pressure, housekeeping pad may not be needed for trap installation

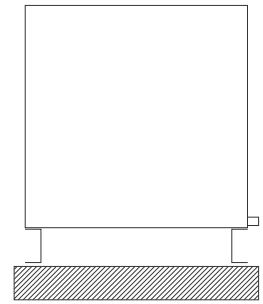

WITH BASE RAIL AND HOUSEKEEPING PAD

FIG. 2 - CONDENSATE DRAIN & TRAPS

LD13929

GENERAL BELT AND BEARING MAINTENANCE

Frequency of bearing re-lubrication depends upon the operating conditions. The proper amount of lubricant in the bearings is very important. Both excessive and inadequate lubrication may cause failure. The bearings should be re-lubricated while they are rotating (if it is safe to do so); the grease should be pumped in slowly until a slight bead forms around the seals. It is solely the owner's responsibility for maintaining a proper lubrication schedule. Failure to do so may cause substantial unit damage and voiding of the factory warranty. Note that only those bearings equipped with a grease fitting can be re-lubricated.

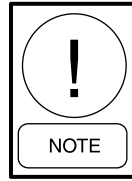

This manual is not intended to supplant regulations or local codes having jurisdiction. It is recommended that these items be reviewed and completed prior to initiating equipment start-up.

The following is a generic guide intended for standard equipment used in common situations.

MAINTENANCE TO BE PERFORMED	EVERY 3 MONTHS OF OPERATION (MINIMUM)	EVERY FALL
Filters (as required)	X	
Grease Bearings	X	
Inspect & Clean Blower Wheel		X
Lubricate Fan Motor (if applicable)		X
Check Belt Tension	X	
Check Electrical Connections		X
Check Bearings, Drives & Blower Wheel for Tightness		X

Normal operation is based on 8 hours a day. If unit runs more than this, adjust accordingly

RECOMMENDED TORQUE FOR TIGHTENING SETSCREWS		
Set Screw Diameter	Minimum Recommended Torque	
	Inch lbs.	Foot lbs.
#10	28	2.3
1/4	66	5.5
5/16	126	10.5
3/8	228	19.0
7/16	348	29.0
1/2	504	42.0
5/8	1104	92.0

LD13904

MOTOR ELECTRICAL DATA

HORSEPOWER	MAXIMUM MOTOR AMPERAGE							
	VOLTAGE							
	115/1	208/1	230/1	277/1	208/3	230/3	460/3	575/3
1/3	6.3	3.5	3.2	2.6	1.7	1.5	0.8	-
1/2	7.8	4.3	3.9	3.6	2.2	2.1	1.1	0.9
3/4	10.6	5.4	5.3	5.0	3.2	3.0	1.5	1.2
1	15.0	8.3	7.5	5.5	4.0	3.6	1.8	1.4
1-1/2	-	-	-	-	5.3	5.0	2.5	1.9
2	-	-	-	-	7.0	6.4	3.2	2.5
3	-	-	-	-	9.1	9.0	4.5	3.2

NOTES:

1. AMPs shown above are NEC full load AMPs for standard motor. Actual motor nameplate AMPs may vary.
2. Consult factory for applications requiring special motors.

UNIT WEIGHT DATA

COMPONENT	UNIT SIZE						
	08	12	16	20	25	30	
BASIC UNIT	125 [57]	131 [60]	160 [73]	167 [76]	231 [105]	236 [107]	
DAMPER SECTION	42 [19]	53 [24]	59 [27]	73 [33]	91 [41]	91 [41]	
BLOW THRU ELECTRIC HEATER	42 [19]	42 [19]	42 [19]	50 [23]	55 [25]	55 [25]	
DISCHARGE COIL SECTION	35 [16]	37 [17]	49 [22]	53 [24]	76 [35]	80 [36]	
SUPPLY PLENUM	22 [10]	26 [12]	35 [16]	38 [17]	76 [35]	76 [35]	
RETURN PLENUM (SSL)	29 [13]	30 [14]	33 [15]	35 [16]	44 [20]	44 [20]	
COIL ROWS	1 ROW - DRY	12 [5]	14 [6]	17 [8]	21 [10]	23 [10]	27 [12]
	1 ROW - WET	14 [6]	17 [8]	21 [10]	26 [12]	28 [13]	34 [15]
	2 ROW - DRY	17 [8]	21 [10]	26 [12]	32 [15]	37 [17]	43 [20]
	2 ROW - WET	21 [10]	27 [12]	33 [15]	42 [19]	48 [22]	56 [25]
	4 ROW - DRY	29 [13]	36 [16]	45 [20]	57 [26]	65 [30]	76 [35]
	4 ROW - WET	37 [17]	47 [21]	58 [26]	75 [34]	86 [39]	101 [46]
	6 ROW - DRY	40 [18]	51 [23]	64 [29]	81 [37]	93 [42]	109 [50]
6 ROW - WET	52 [24]	66 [30]	84 [38]	109 [50]	124 [56]	146 [66]	

NOTES:

1. Unit weight data is shipping weight in pounds (kilograms).
2. Discharge section includes a 2 row coil.

MOTOR/DRIVE WEIGHT DATA

TYPE	MOTOR HP						
	1/3	1/2	3/4	1	1 1/2	2	3
SINGLE PHASE	37 [17]	37 [17]	45 [20]	47 [21]	--	--	--
THREE PHASE	34 [15]	34 [15]	40 [18]	43 [20]	46 [21]	53 [24]	81 [37]

LD13905

MODEL SSL ARRANGEMENTS

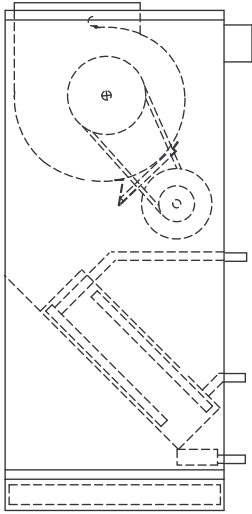

**Reverse Rotation
Arrangement 1**

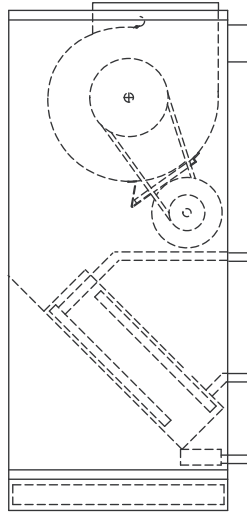

**Standard Rotation
Arrangement 2**

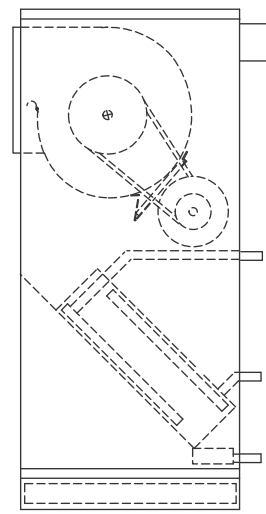

**Horizontal Rear Discharge
Arrangement 7**

MODEL SBS ARRANGEMENTS

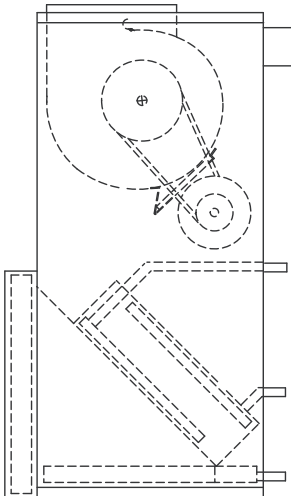

**Reverse Rotation
Arrangement 1**

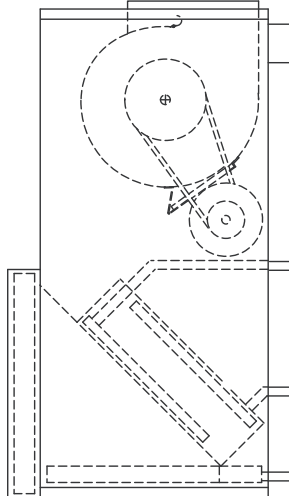

**Standard Rotation
Arrangement 2**

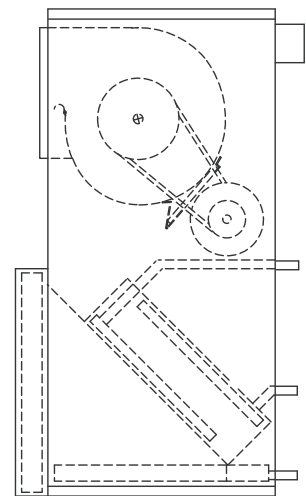

**Horizontal Rear Discharge
Arrangement 7**

NOTES:

1. Refer to Dimensional Data for unit dimensions.
2. Fan arrangements are also available with inlet damper section (Model SBS) and return plenum section (Model SSL).
3. Side access filter rack standard on arrangement 7 (Model SBS).
4. Discharge heating coil section and supply plenum are not available with arrangement 7.
5. All drawings subject to change without prior notice. Refer to www.superiorrex.com for current submittal drawings.

LD13906

INSPECTION & START-UP CHECKLIST

Receiving & Inspection

- Unit Received Undamaged
- Unit Arrangement/Hand Correct
- Unit Received Complete As Ordered
- Unit Structural Support Complete & Correct

Handling & Installation

- Unit Mounted Level & Square
- Proper Electrical Service Provided
- Proper Service Switch/Disconnect Provided
- Proper Chilled Water Line Size To Unit
- Proper Steam Condensate Trap On Return Line
- All Services To Unit In Code Compliance
- Proper Access Provided for Unit & Accessories
- Proper Overcurrent Protection Provided
- Proper Hot Water Line To Unit
- Proper Steam Line Sizes To Unit
- Proper Steam Supply Pressure To Unit (15psi Max)
- All Shipping Screws & Braces Removed

Cooling/Heating Connections

- Protect Valve Package Components From Heat
- Connect Field Piping To Unit
- Install Drain Line & Traps As Required
- Install Condensate Pan Under Piping As Required
- Mount Valve Packages
- Pressure Test All Piping For Leaks
- Insulate All Piping As Required

Ductwork Connections

- Install Ductwork, Fittings & Grilles As Required
- Control Outside Air For Freeze Protection
- Proper Supply & Return Grille Type & Size Used
- Insulate All Ductwork As Required

Electrical Connections

- Refer To Unit Wiring Diagram
- All Field Wiring In Code Compliance
- Connect Incoming Power Service or Services

Unit Startup

- General Visual Unit & System Inspection
- Record Ambient Temperature
- Close All Unit Isolation Valves
- Fill Systems With Water/Refrigerant
- All Ductwork & Grilles In Place
- Start Fans, Etc.
- Check All Ductwork & Units For Air Leaks
- Record All Final Settings For Future Use
- Check All Dampers For Proper Operation
- Verify Proper Heating Operation
- Record Electrical Supply Voltage
- Check All Wiring For Secure Connections
- Flush Water Systems
- Vent Water Systems As Required
- All Unit Panels & Filters In Place
- Check For Overload Condition Of All Units
- Balance Air Systems As Required
- Check Piping & Ductwork For Vibration
- Verify Proper Cooling Operation
- Reinstall All Covers & Access Panels

Blower/Motor

- Check Sheave Set Screw Tightness
- Check Blower Wheel Set Screw Tightness
- Adjust Blower Speed as Necessary for Balancing Airflow
- Check/Adjust Sheave Alignment
- Check/Adjust Belt Tension

LD13907

DIMENSIONS

Model SSL Basic Unit - Discharge Arrangement 2

NOTES:

1. All dimensions are Inches [millimeters].
All dimensions are $\pm 1/4"$ [6mm]. Metric values are soft conversion.
2. Left hand unit shown.
Motor/drive location may be specified Left or Right Hand. Standard control enclosure location matches motor/drive position. Enclosure size varies with options.
3. Provide sufficient clearance to access electrical controls and comply with all applicable codes and ordinances.
4. Optional base rail designed for use with floor mount vibration isolators.

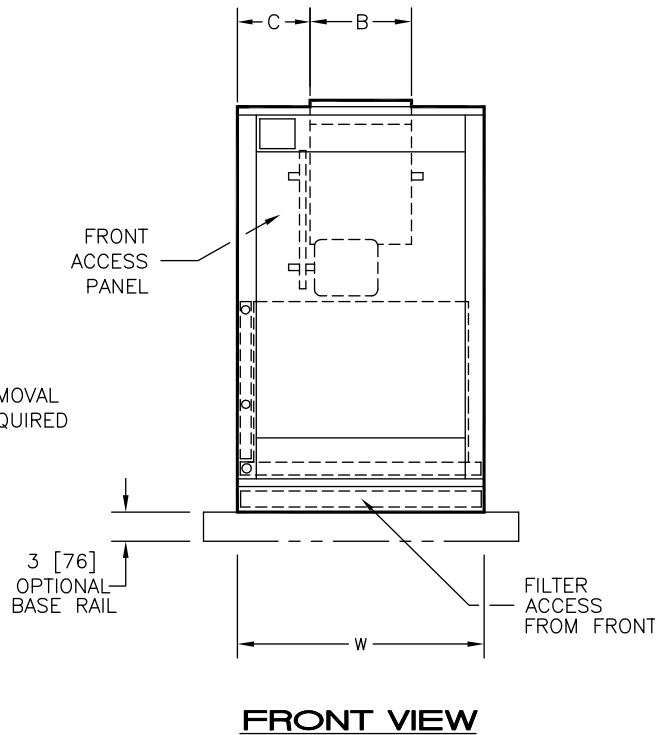
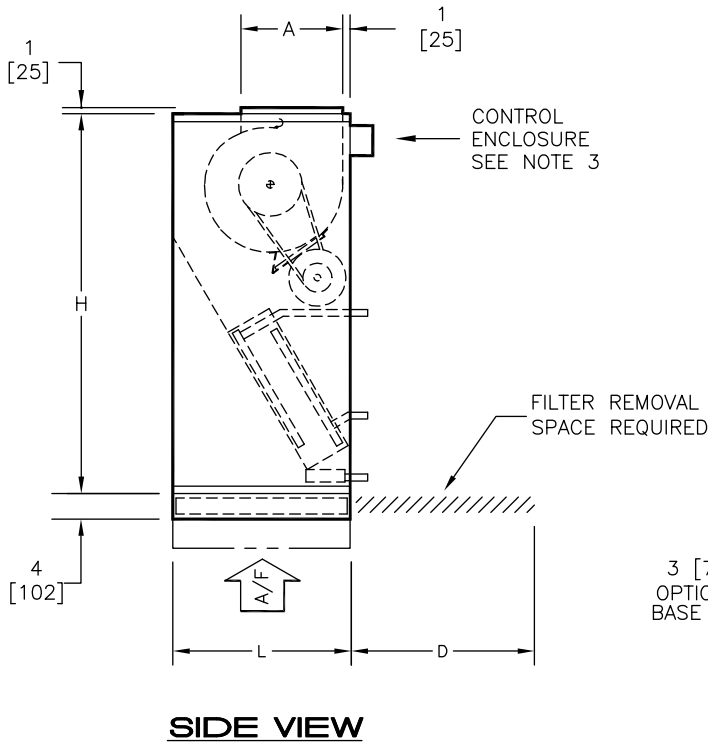
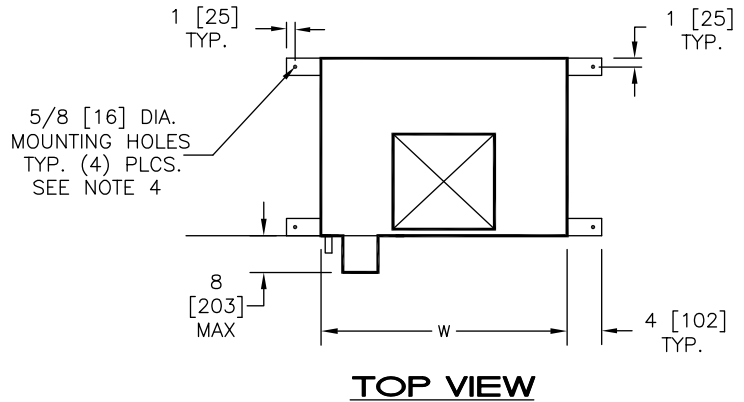

DIMENSIONS - In [mm]

52-80004REV01

UNIT SIZE	FILTER SIZE	QTY	H	W	L	A	B	C	D
08	16 X 20 X 2 [406 X 508 X 51]	1	46 [1168]	26 [660]	19 [483]	6-1/2 [165]	6-7/8 [175]	9-9/16 [243]	16 [406]
12	20 X 20 X 2 [508 X 508 X 51]	1	46 [1168]	26 [660]	21 [533]	7-1/2 [190]	8-1/4 [210]	8-7/8 [225]	20 [508]
16	24 X 24 X 2 [610 X 610 X 51]	1	54 [1372]	29 [737]	25 [635]	7-1/2 [190]	10-1/4 [260]	9-3/8 [238]	24 [610]
20	24 X 24 X 2 [610 X 610 X 51]	1	54 [1372]	29 [737]	28 [711]	11-3/8 [289]	13-1/4 [337]	7-7/8 [200]	24 [610]
25	24 X 24 X 2 [610 X 610 X 51]	1 EACH	60 [1524]	39 [991]	28 [711]	16 [406]	12-7/8 [327]	13-1/16 [332]	24 [610]
30	12 X 24 X 2 [305 X 610 X 51]	1 EACH	60 [1524]	39 [991]	28 [711]	16 [406]	15 [381]	12 [305]	24 [610]

Model SSL Basic Unit - Discharge Arrangement 1 with Blow-thru Electric Heat

NOTES:

1. All dimensions are Inches [millimeters]. All dimensions are $\pm 1/4"$ [6mm]. Metric values are soft conversion.
2. Left hand unit shown. Motor/drive location may be specified Left or Right Hand. Standard control enclosure location matches motor/drive position.
3. Provide sufficient clearance to access electrical controls and comply with all applicable codes and ordinances.
4. Optional base rail designed for use with floor mount vibration isolators.
5. Blow-thru electric heat may not be combined with supply plenum or discharge section.

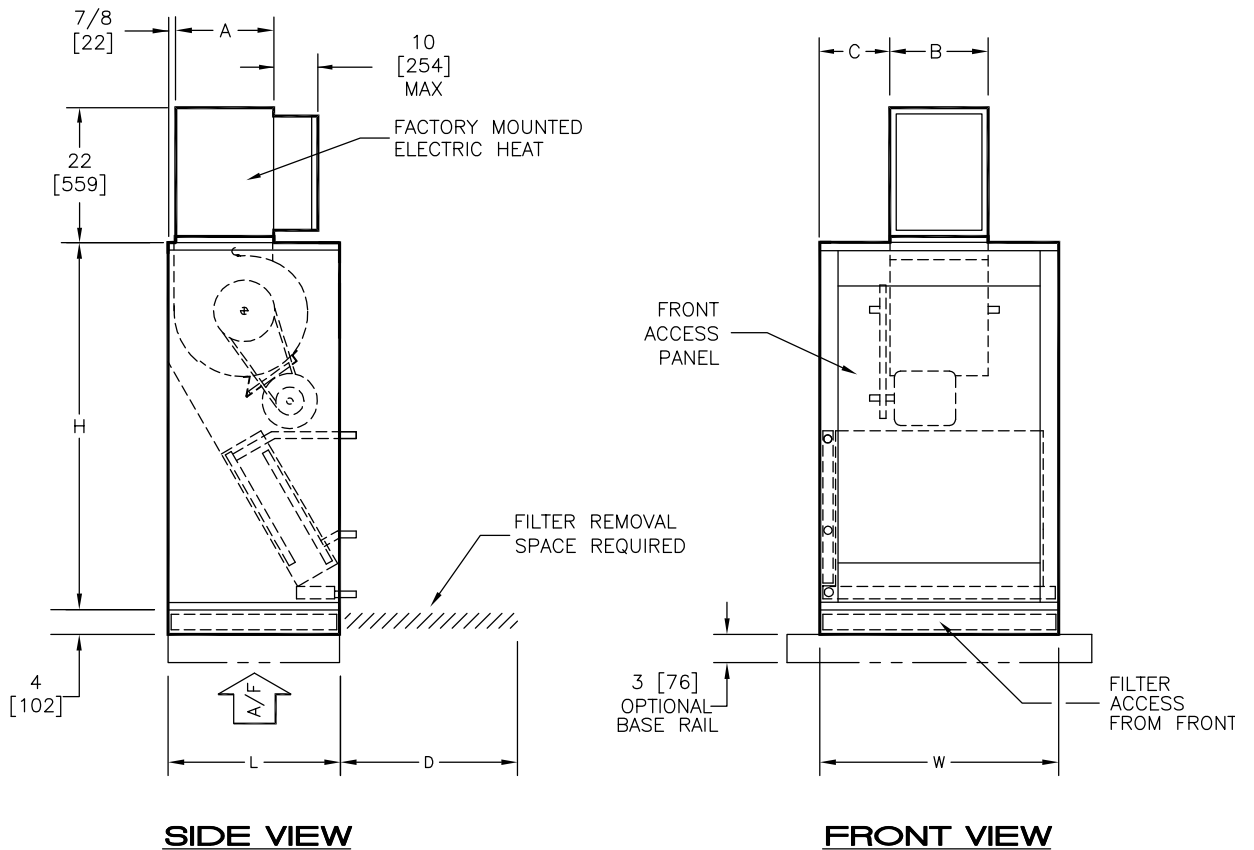
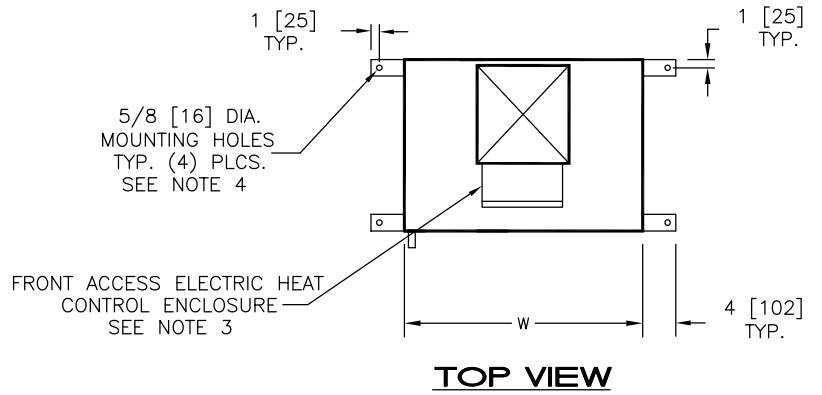

DIMENSIONS - In [mm]

52-80011REV01

UNIT SIZE	FILTER SIZE	QTY	H	W	L	A	B	C	D
08	16 X 20 X 2 [406 X 508 X 51]	1	46 [1168]	26 [660]	19 [483]	8-7/8 [226]	11-7/8 [302]	7-1/16 [180]	16 [406]
12	20 X 20 X 2 [508 X 508 X 51]	1	46 [1168]	26 [660]	21 [533]	8-7/8 [226]	11-7/8 [302]	7-1/16 [180]	20 [508]
16	24 X 24 X 2 [610 X 610 X 51]	1	54 [1372]	29 [737]	25 [635]	10-7/8 [277]	12 [305]	8-1/2 [216]	24 [610]
20	24 X 24 X 2 [610 X 610 X 51]	1	54 [1372]	29 [737]	28 [711]	13-7/8 [353]	14 [356]	7-1/2 [190]	24 [610]
25	24 X 24 X 2 [610 X 610 X 51]	1 EACH	60 [1524]	39 [991]	28 [711]	13-7/8 [353]	16-5/8 [422]	11-1/16 [281]	24 [610]
30	12 X 24 X 2 [305 X 610 X 51]	1 EACH	60 [1524]	39 [991]	28 [711]	15 5/8 [397]	16-5/8 [422]	11-1/16 [281]	24 [610]

Model SBS Basic Unit - Discharge Arrangement 2

NOTES:

1. All dimensions are Inches [millimeters].
All dimensions are $\pm 1/4"$ [6mm]. Metric values are soft conversion.
2. Left hand unit shown.
Motor/drive location may be specified Left or Right Hand. Standard control enclosure location matches motor/drive position.
Enclosure sizes varies with option.
3. Provide sufficient clearance to access electrical controls and comply with all applicable codes and ordinances.
4. Optional base rail designed for use with floor mount vibration isolators.

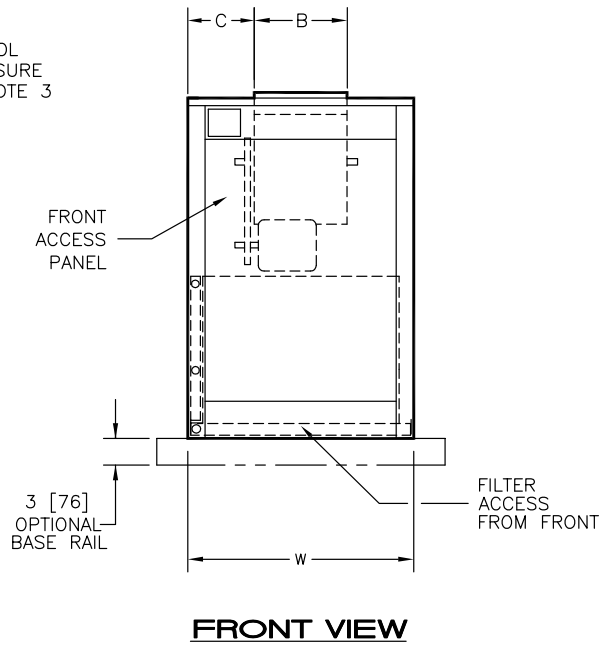
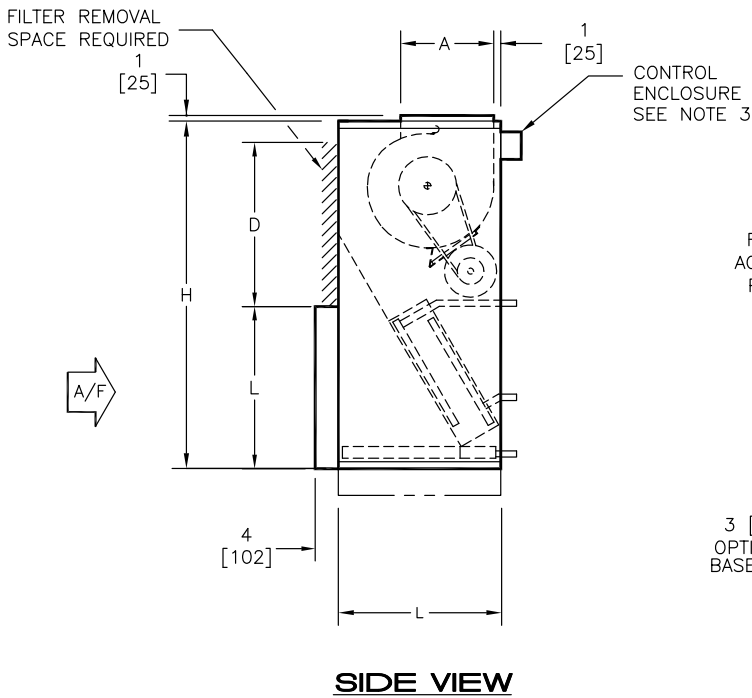
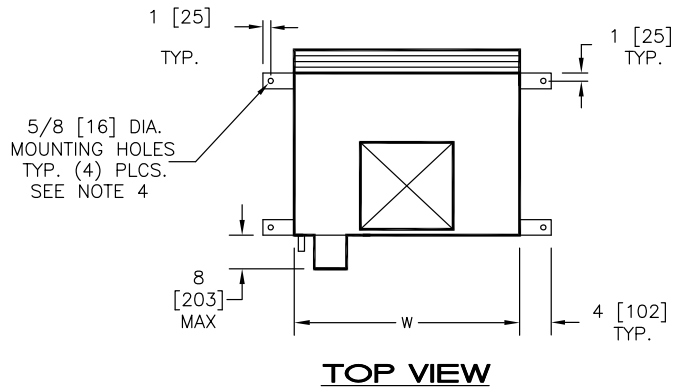

DIMENSIONS - In [mm]

52-80007REV01

UNIT SIZE	FILTER SIZE	QTY	H	W	L	A	B	C	D
08	16 X 20 X 2 [406 X 508 X 51]	1	46 [1168]	26 [660]	19 [483]	6-1/2 [165]	6-7/8 [175]	9-9/16 [243]	16 [406]
12	20 X 20 X 2 [508 X 508 X 51]	1	46 [1168]	26 [660]	21 [533]	7-1/2 [190]	8-1/4 [210]	8-7/8 [225]	20 [508]
16	24 X 24 X 2 [610 X 610 X 51]	1	54 [1372]	29 [737]	25 [635]	7-1/2 [190]	10-1/4 [260]	9-3/8 [238]	24 [610]
20	24 X 24 X 2 [610 X 610 X 51]	1	54 [1372]	29 [737]	28 [711]	11-3/8 [289]	13-1/4 [337]	7-7/8 [200]	24 [610]
25	24 X 24 X 2 [610 X 610 X 51]	1 EACH	60 [1524]	39 [991]	28 [711]	16 [406]	12-7/8 [327]	13-1/16 [332]	24 [610]
30	12 X 24 X 2 [305 X 610 X 51]	1 EACH	60 [1524]	39 [991]	28 [711]	16 [406]	15 [381]	12 [305]	24 [610]

Model SBS with Inlet Damper Section (Requires Base rail) - Discharge Arrangement 2

NOTES:

1. All dimensions are Inches [millimeters].
All dimensions are $\pm 1/4"$ [6mm]. Metric values are soft conversion.
2. Left hand unit shown. Right hand unit opposite.
Motor/drive location may be specified
Left or Right Hand. Standard control enclosure location matches motor/drive position.
3. Provide sufficient clearance to access electrical controls and comply with all applicable codes and ordinances.
4. Base rail designed for use with floor mount vibration isolators. See page 16 for base rail details.

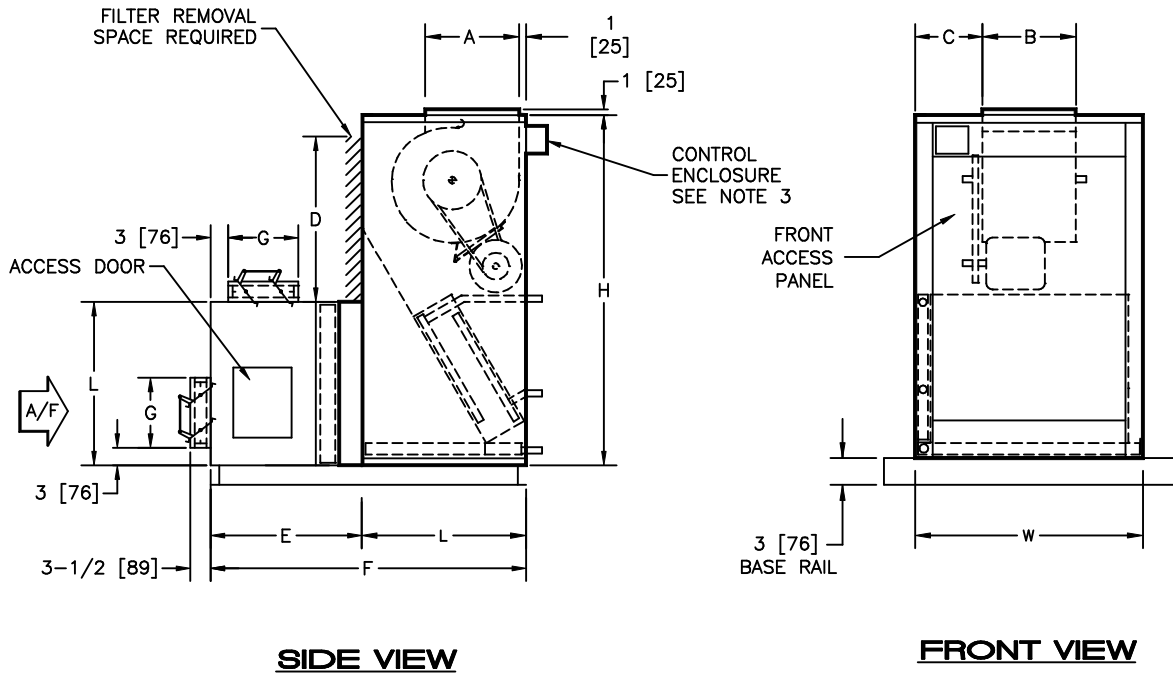
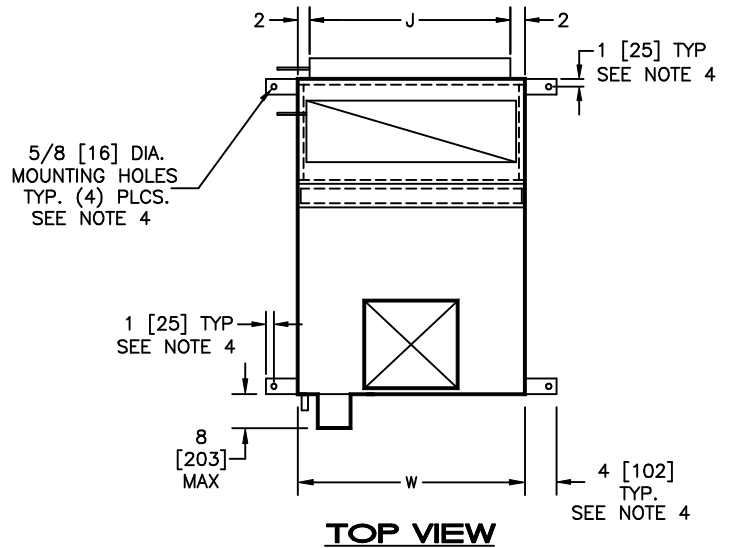

DIMENSIONS - In [mm]

52-80020REV00

UNIT SIZE	FILTER SIZE	QTY	H	W	L	A	B	C	D	E	F	G	J
08	16 X 20 X 2 [406 X 508 X 51]	1	46 [1168]	26 [660]	19 [483]	6-1/2 [165]	6-7/8 [175]	9-9/16 [243]	16 [406]	15 [381]	35 [889]	6 [152]	22 [559]
12	20 X 20 X 2 [508 X 508 X 51]	1	46 [1168]	26 [660]	21 [533]	7-1/2 [190]	8-1/4 [210]	8-7/8 [225]	20 [508]	18 [457]	40 [1016]	9 [229]	22 [559]
16	24 X 24 X 2 [610 X 610 X 51]	1	54 [1372]	29 [737]	25 [635]	7-1/2 [190]	10-1/4 [260]	9-3/8 [236]	24 [610]	18 [457]	44 [1118]	9 [229]	25 [635]
20	24 X 24 X 2 [610 X 610 X 51]	1	54 [1372]	29 [737]	28 [711]	11-3/8 [289]	13-1/4 [337]	7-7/8 [200]	24 [610]	21 [533]	50 [1270]	12 [305]	25 [635]
25	24 X 24 X 2 [610 X 610 X 51]	1 EACH	60 [1524]	39 [991]	28 [711]	16 [406]	12-7/8 [327]	13-1/16 [332]	24 [610]	21 [533]	50 [1270]	12 [305]	35 [889]
30	12 X 24 X 2 [305 X 610 X 51]	1 EACH	60 [1524]	39 [991]	28 [711]	16 [406]	15 [381]	12 [305]	24 [610]	21 [533]	50 [1270]	12 [305]	35 [889]

3 Inch Baserail Assembly

NOTES:

1. All dimensions are Inches [millimeters].
All dimensions $\pm 1/4"$ [6mm].
2. Vertical unit shown, typical for both vertical and horizontal units.
3. Support used on units with length over 50 [1270].

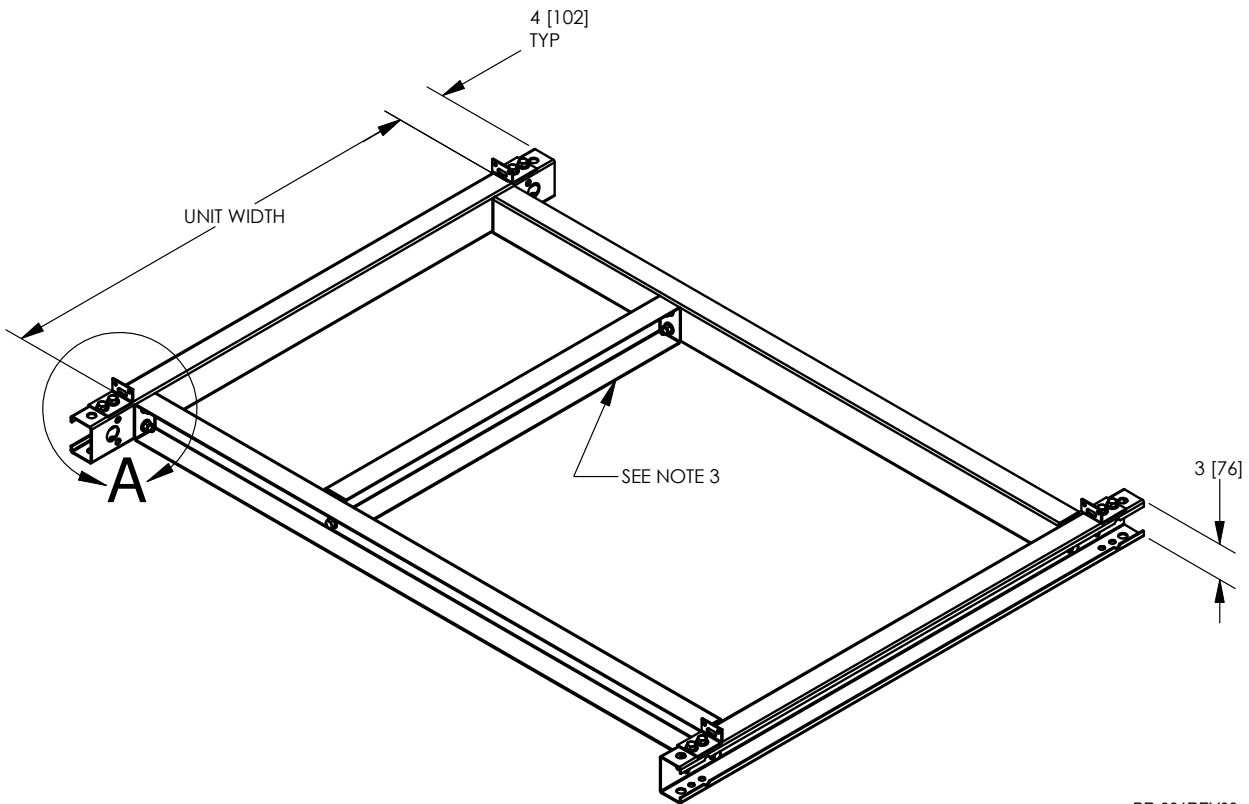
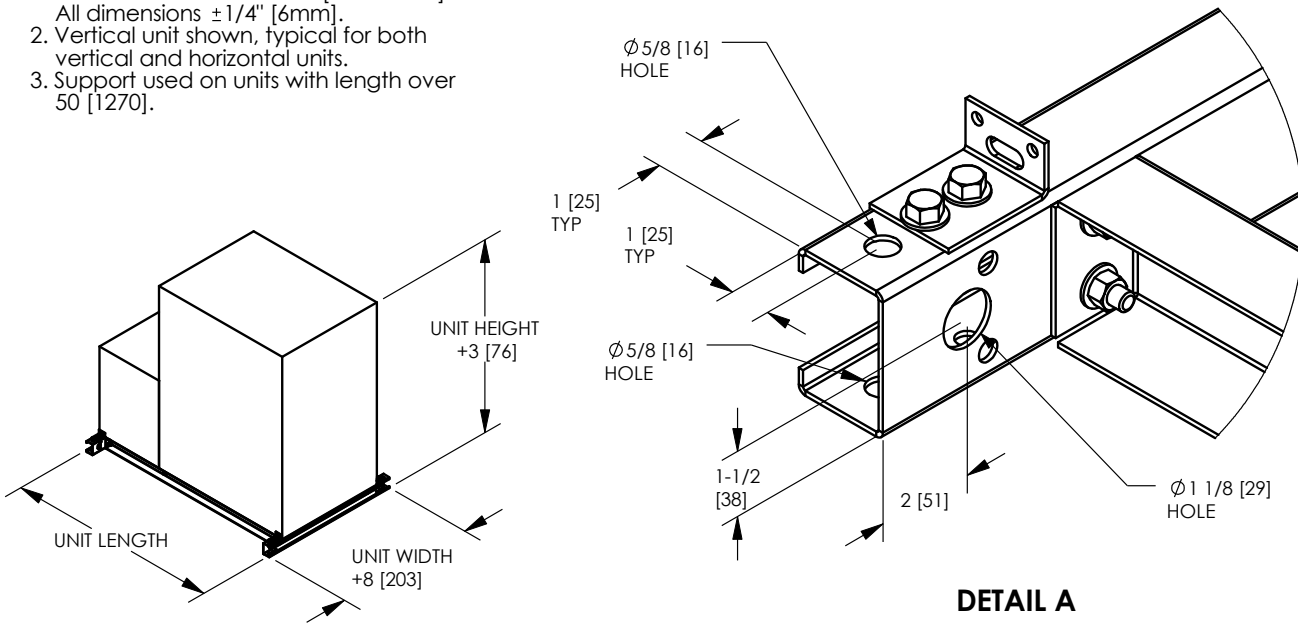

BR-001REV03

Model SSL/SBS Discharge Plenum, Sizes 08-30

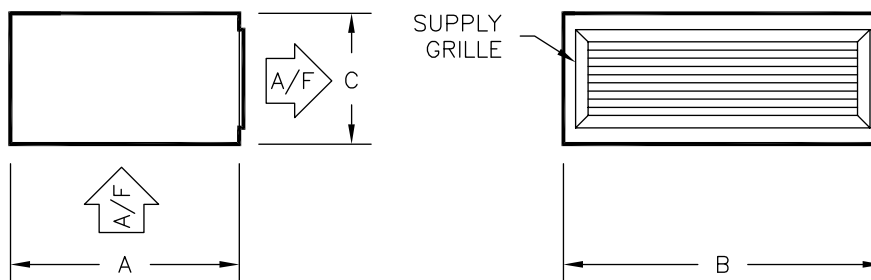

Side View

Front View

DIMENSIONS - In [mm]

UNIT SIZE	A	B	C	SUPPLY GRILLE
08	19 [483]	26 [660]	12 [305]	18 X 8 [457 X 203]
12	21 [533]	26 [660]	12 [305]	22 X 8 [559 X 203]
16	25 [635]	29 [737]	14 [356]	24 X 10 [610 X 254]
20	28 [711]	29 [737]	16 [406]	24 X 12 [610 X 305]
25	28 [711]	39 [991]	16 [406]	30 X 12 [762 X 305]
30	28 [711]	39 [991]	16 [406]	36 X 12 [914 X 305]

NOTES:

1. All dimensions are Inches [millimeters].
All dimensions are $\pm 1/4"$ [6mm]. Metric values are soft conversion.
2. Discharge plenum shipped attached to unit.
3. Discharge plenum includes a double deflection discharge grille, location is front as shown.
4. Discharge plenum may not be combined with blow thru electric heat.

Model SSL Return Plenum, Sizes 08-30

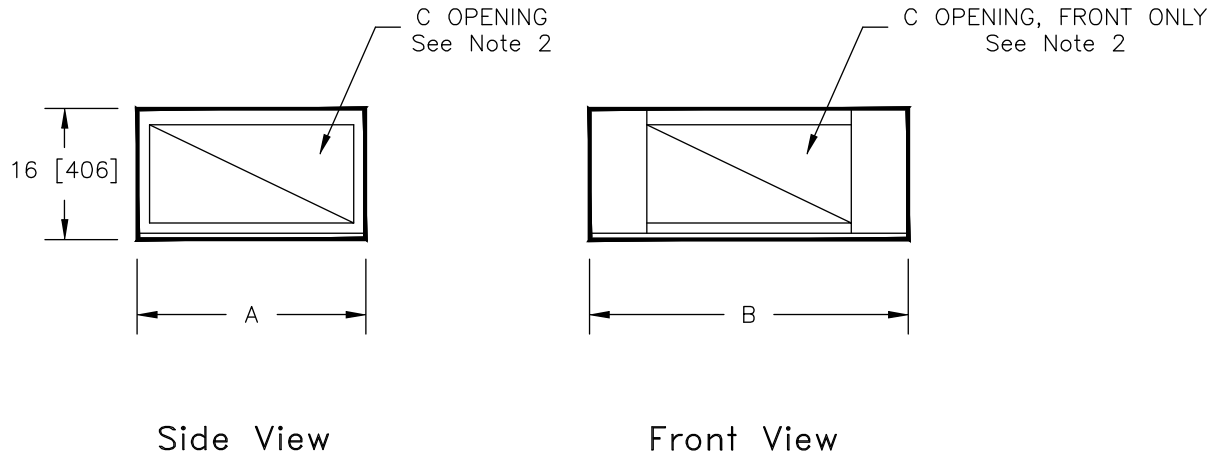

DIMENSIONS - In [mm]

UNIT SIZE	A	B	C OPENING
08	19 [483]	26 [660]	9 X 16 [229 X 406]
12	21 [533]	26 [660]	9 X 18 [229 X 457]
16	25 [635]	29 [737]	9 X 22 [229 X 559]
20	28 [711]	29 [737]	12 X 22 [305 X 559]
25	28 [711]	39 [991]	12 X 25 [305 X 635]
30	28 [711]	39 [991]	12 X 25 [305 X 635]

NOTES:

1. All dimensions are inches [millimeters]. All dimensions $\pm 1/4"$ [6mm]. Metric values are soft conversion.
2. Standard plenum is provided with removable covers on side openings, and plenum is installed on unit for front inlet. Covers may be relocated, and plenum may be rotated in the field for alternate inlet locations.

52-80017REV00

Model SSL/SBS Discharge Section w/ Heating Coil, Sizes 08-30

- NOTES:**
1. All dimensions $\pm 1/4"$ [6mm].
 2. This section required with 6 row cooling in conjunction with hot water and all steam heating.
 3. Weight with 2 row dry coil.
 4. Coil connection dimension $\pm 1/2"$ [13mm].
 5. Hot water coils: Supply - bottom, Return - top.
Steam coils: Supply - top, Condensate - bottom.
 6. Discharge section may not be combined with Blow-Thru Electric Heat.

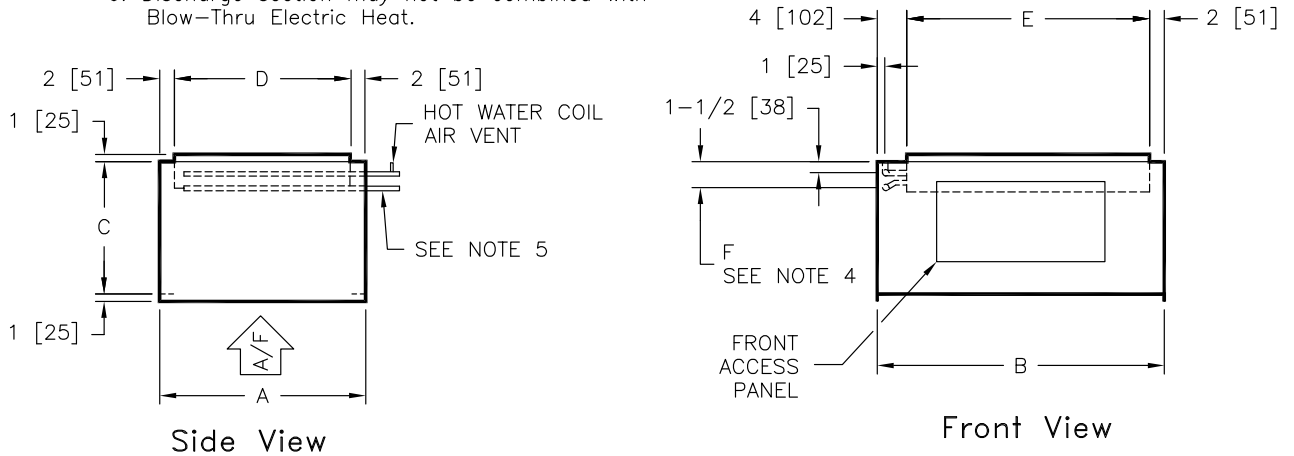

DIMENSIONS - In [mm]

UNIT SIZE	A	B	C	D	E	F (4)				WGT. (3) lbs. [kg]
						HOT WATER		STEAM		
						1 ROW	2 ROW	1 ROW	2 ROW	
08	19 [483]	26 [660]	12 [305]	15 [381]	20 [508]	2-3/4 [70]	2-3/4 [70]	2-3/4 [70]	2-3/4 [70]	35 [16]
12	21 [533]	26 [660]	12 [305]	17 [432]	20 [508]	2-3/4 [70]	2-3/4 [70]	2-3/4 [70]	2-3/4 [70]	37 [17]
16	25 [635]	29 [737]	14 [356]	21 [533]	23 [584]	2-3/4 [70]	3 [76]	2-3/4 [70]	3-1/4 [83]	49 [22]
20	28 [711]	29 [737]	14 [356]	24 [610]	23 [584]	2-3/4 [70]	3 [76]	3-1/4 [83]	3-1/4 [83]	53 [24]
25	28 [711]	39 [991]	18 [457]	24 [610]	33 [838]	2-3/4 [70]	3 [76]	3-1/4 [83]	3-3/4 [95]	76 [35]
30	28 [711]	39 [991]	18 [457]	24 [610]	33 [838]	3 [76]	3-1/4 [83]	3-3/4 [95]	3-3/4 [95]	80 [36]

COIL CONNECTION SIZES

UNIT SIZE	HOT WATER		STEAM			
	1 ROW	2 ROW	1 ROW		2 ROW	
			SUPPLY	CONDENSATE	SUPPLY	CONDENSATE
08	5/8 [16]	5/8 [16]	1-1/8 [29]	7/8 [22]	1-1/8 [29]	7/8 [22]
12	5/8 [16]	5/8 [16]	1-1/8 [29]	7/8 [22]	1-1/8 [29]	7/8 [22]
16	5/8 [16]	5/8 [16]	1-1/8 [29]	7/8 [22]	1-3/8 [35]	1-1/8 [29]
20	5/8 [16]	5/8 [16]	1-3/8 [35]	1-1/8 [29]	1-3/8 [35]	1-1/8 [29]
25	5/8 [16]	7/8 [22]	1-3/8 [35]	1-1/8 [29]	1-5/8 [41]	1-1/8 [29]
30	7/8 [22]	7/8 [22]	1-5/8 [41]	1-1/8 [29]	1-5/8 [41]	1-1/8 [29]

© 2025 Air Distribution Technologies IP, LLC.

Product and service names referenced herein are trademarks of Air Distribution Technologies IP, LLC in the United States and other countries and regions. All product specifications reflect the available information at the time of printing this brochure. Air Distribution Technologies IP, LLC is a subsidiary of Air Distribution Technologies, which reserves the right to revise or modify products and/or specifications without notice.

