

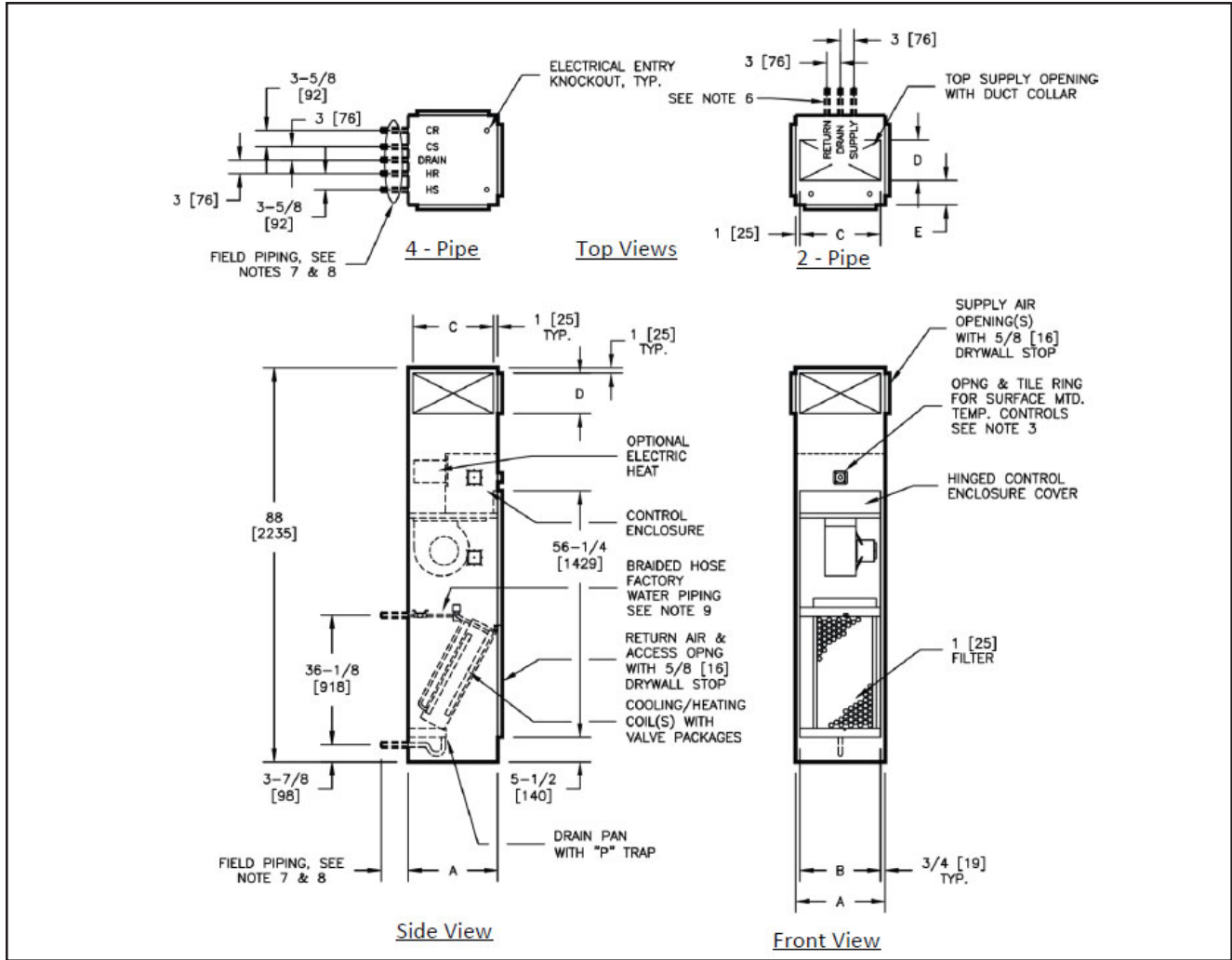

RARS SECONDARY CONCEALED UNIT



Unit Size	A	B	Single Supply		E
			C	D	
03 & 04	18 [457]	16 1/2 [419]	16 [406]	8 [203]	6 [152]
06 & 08	20 [508]	18 1/2 [470]	18 [457]	12 [305]	6 [152]
10 & 12	24 [610]	22 1/2 [572]	22 [559]	14 [356]	8 [203]

Notes:

1. All dimension are inches [mm]. Metric values are soft conversions.
2. All dimensions are ±1/4 [6mm]
3. Tile ring is installed on front of unit as shown, and may be moved to left or right side of unit in field. The ring omitted on units with "ADA" control mounting location.
4. Wiring from electrical entry point to control enclosure is furnished and installed by others in field
5. All piping and insulation between Primary and Secondary units is furnished and installed in the field by others
6. All coil and drain connections are "retracted" and braced internally for shipment
7. Coil connections are 5/8" [16mm] O.D. female sweat. Drain "P-trap" is designed to accept 7/8" [22mm] O.D copper tube
8. Secondary units are furnished with factory installed shutoff valves and field connection tubes, unless Primary unit risers are shipped loose